

LG16

Media Isolated Microfluidic Flow Sensor

- Liquid flow rates up to 5000 µl/min
- Resolutions down to sub nl/min
- Totally non invasive, pressures up to 200 bar
- Digital I²C interface or analog out 0-5 V

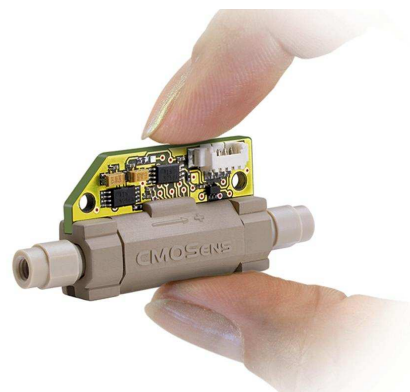

1 Introduction LG16

The LG16 Liquid Flow Sensor series enables fast, non invasive measurements of very low liquid flow rates below 5 ml/min. This product line is especially suited for OEM volume applications requiring small sized components with high performance at low cost. Excellent chemical resistance and bio-compatibility are ensured: The flow path of the LG16 Liquid Flow Sensors is formed by a simple, straight glass capillary. This Swiss made, non invasive sensors are based on Sensirion's patented CMOSens® Technology (US Patent 6,813,944 B2). The fourth generation MEMS sensors combine a thermal high precision sensor element with amplification circuits and digital intelligence for linearization and temperature compensation on one single microchip – the products core element.

2 Sensing Performance

Table 1: Model specific performance of LG16 (all data for medium H₂O, 20°C, 1 bar_{abs} unless otherwise noted)

Parameter	LG16-0025	LG16-0150	LG16-0480	LG16-1000	LG16-2000	
Maximum Flow Rate	1.50	7.00	50	1000	5000	µl/min
Lowest Calibrated Flow (LCF)	0.07	0.4	1.0	30	200	µl/min
Digital Resolution at LCF (16 bit)	0.084	0.24	0.60	12	150	nl/min
Accuracy ^a above LCF	10	5.0	5.0	5.0	5.0	% of m.v. ^b
Accuracy below LCF	0.5	0.25	0.1	0.15	0.2	% of full scale
Signal Noise, 16 bit digital output	4.5	4.5	4.5	4.5	4.5	LSB
- at LCF	0.002	0.010	0.025	0.25	3.0	µl/min
- at Maximum Flow Rate	0.004	0.040	0.300	5.0	20	µl/min
Signal Noise, analog output, RMS	< 2					mV
Temperature Coefficient	0.15	0.09	0.13	0.1	0.1	(% m.v. ^b) / K
Mounting Orientation Sensitivity ^c	-	<0.4	<0.4	1.0	1.5	% of full scale
Flow Detection Response Time τ ₆₃	40			40		ms
Response Time On Power-Up	120			120		ms
Digital Sampling Rate, 16 bit	74			74		ms
Digital Sampling Rate, 9 bit	1			1		ms
Operating Temperature	+10...+50			+10...+50		°C
Ambient storage temperature	-10...+60			-10...+60		°C

3 Output Signals

The OEM flow sensor LG16 shows bi-directional, linear transfer characteristics. The product comes fully calibrated for water – for volume applications flow calibration for methanol or other media is available on request.

^a Better available on request.

^b Measured value

^c Normal position: Horizontal flow channel

The LG16 can be ordered as analog output version (0...5V, LG16-xxxx-A) or as digital output version (LG16-xxxx-D). Digital communication between a master and the LG16-xxxx-D sensor runs via the standard I²C-interface. The physical interface consists of two bus lines, a data line (SDA) and a clock line (SCL). These lines can be used on 3.3V or 5.0V level with a clock frequency of 100 kHz. For the detailed specifications of this I²C communication refer to the Sensirion "User Manual I²C-Mode SF04".

4 Electrical and Mechanical Specifications

4.1 Electrical Specifications

Table 2: DC Characteristics.

Parameter	Conditions	Min.	Typ.	Max.	Units
Power Supply DC, VDD	for digital out I ² C type	3.5	7.0	12 ^a	V
	for analog out type	6.0	7.0	12 ^a	V
Operating Current	V _{DD} = 3.5 V, no load		6.8		mA
	V _{DD} = 12 V, no load		6.8		mA
Analog Out Voltage Range	negative to positive maximum flow (LG16-xxxx-A only), zero flow =2.5V	0.2		4.8	V
Load at Analog Out		10		∞	kΩ

Table 3: I²C Output Characteristics

Parameter	Conditions	Min.	Typ.	Max.	Units
I ² C Bus Clock Frequency			100		kHz
Output Voltage Low (SDA/SCL)	I _{sink} = 6mA		0.1	0.5	V
Low Level Output Current(SDA/SCL)				6	mA
High Level Input Voltage (SDA/SCL)		2.0			V
Low Level Input Voltage (SDA/SCL)				1.0	V

4.2 Electrical Connector and Pinout

Connector Type: 5 pin Molex PCB Header 53261-0590 (right angle) . Assembled flat ribbon cable Molex 1.25 mm Pitch Rectacle Type 51021-0500 (PicoBlade™ 51021) included.

Pin	
1	SDA (bi-directional)
2	SCL
3	VDD
4	GND
5	Analog out

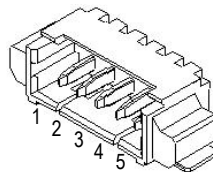

4.3 Electrical Connection for Digital Communication via I²C

Digital communication between LG16-xxxx-D type sensors and an I²C master works on both 5V or 3.3V level. The SDA and SCL lines need to be connected via pull-up resistors with the bus voltage of the system. The individual I²C address of each sensor on the I²C bus can be set with a special interface tool.

^a Keep supply voltage below 9V for high precision applications; exceeding 12V will lead to permanent damage of the sensor

4.4 Mechanical Specifications and Pressure Rating

Inside the LG16 flow sensors a highly sensitive microsensor-chip is mounted on the outside of a straight glass capillary and allows to measure the flow through the wall (US Patent 6,813,944 B2) using a thermal principle.

Table 4: Mechanical Specifications and Pressure Rating

Parameter	LG16-0025	LG16-0150	LG16-0480	LG16-1000	LG16-2000
Fluid Connector Ports (Fittings)	UNF 6-40 for 1/32" OD tubing VICI® (Valco) Nanovolume™ compatible			1/4-28 for 1/16" or 1/8" OD plastic tubing	
Wetted Materials:					
<ul style="list-style-type: none"> Internal Sensor Capillary Material 	Quartz Glass (Fused Silica)			Borosilicate Glass 3.3 (Duran®)	
<ul style="list-style-type: none"> Fitting Material 	100% PEEK™ (polyetheretherketone)				
<ul style="list-style-type: none"> Additional Sealing Material 	None			Teflon®	ETFE(Tefzel®)
Overpressure Resistance	200 bar 2900 psi		100 bar 1450 psi	5 bar 70 psi	3 bar 40 psi
Maximum Pressure Drop (at max. flow rate)	1.5 bar	5 mbar	5 mbar	2 mbar	1 mbar
Internal Sensor Capillary, Inner Diameter	25 µm	150 µm	480 µm	1.0 mm	1.8 mm
Total Internal Volume	1 µl	1.5 µl	6.5 µl	<30 µl	<90 µl
Total Mass	6 g				

Attention Fragile	
<p>Mechanical shocks and connecting to the fittings without suitable tools leads to stress on the internal thin walled glass capillary and can cause it to break.</p> <ul style="list-style-type: none"> While tightening the fittings, fix the fluidic ports position with a wrench. Test for leakage after every time new connections are made. 	!

5 Physical Dimensions

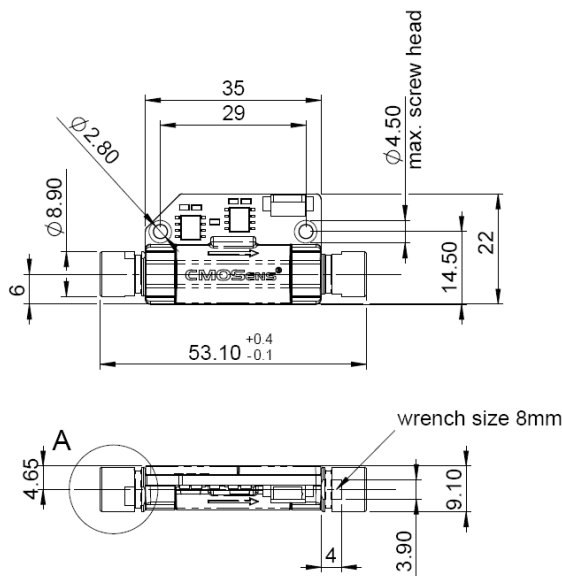

6 Ordering Information

The LG16 flow sensors can be ordered for OEM volume applications. Each model is available with analog output (ending "-A") or with digital output (ending "-D"). Fluid connection material is not included.

Product	Article Number
LG16-2000-A	1-100403-01
LG16-2000-D	1-100404-01
LG16-1000-A	1-100405-01
LG16-1000-D	1-100406-01
LG16-0480-A	1-100407-01
LG16-0480-D	1-100408-01
LG16-0150-A	1-100409-01
LG16-0150-D	1-100410-01
LG16-0025-A	1-100427-01
LG16-0025-D	1-100428-01

7 Important Notices

7.1 Warning, personal injury

Do not use this product as safety or emergency stop devices or in any other application where failure of the product could result in personal injury. Do not use this product for applications other than its intended and authorized use. Before installing, handling, using or servicing this product, please consult the data sheet and application notes. Failure to comply with these instructions could result in death or serious injury.

If the Buyer shall purchase or use SENSIRION products for any unintended or unauthorized application, Buyer shall defend, indemnify and hold harmless SENSIRION and its officers, employees, subsidiaries, affiliates and distributors against all claims, costs, damages and expenses, and reasonable attorney fees arising out of, directly or indirectly, any claim of personal injury or death associated with such unintended or unauthorized use, even if SENSIRION shall be allegedly negligent with respect to the design or the manufacture of the product.

7.2 ESD Precautions

The inherent design of this component causes it to be sensitive to electrostatic discharge (ESD). To prevent ESD-induced damage and/or degradation, take customary and statutory ESD precautions when handling this product.

See application note "ESD, Latchup and EMC" for more information.

7.3 Warranty

SENSIRION warrants solely to the original purchaser of this product for a period of 12 months (one year) from the date of delivery that this product shall be of the quality, material and workmanship defined in SENSIRION's published specifications of the product. Within such period, if proven to be defective, SENSIRION shall repair and/or replace this product, in SENSIRION's discretion, free of charge to the Buyer, provided that:

- notice in writing describing the defects shall be given to SENSIRION within fourteen (14) days after their appearance;
- such defects shall be found, to SENSIRION's reasonable satisfaction, to have arisen from SENSIRION's faulty design, material, or workmanship;
- the defective product shall be returned to SENSIRION's factory at the Buyer's expense; and
- the warranty period for any repaired or replaced product shall be limited to the unexpired portion of the original period.

This warranty does not apply to any equipment which has not been installed and used within the specifications

recommended by SENSIRION for the intended and proper use of the equipment. EXCEPT FOR THE WARRANTIES EXPRESSLY SET FORTH HEREIN, SENSIRION MAKES NO WARRANTIES, EITHER EXPRESS OR IMPLIED, WITH RESPECT TO THE PRODUCT. ANY AND ALL WARRANTIES, INCLUDING WITHOUT LIMITATION, WARRANTIES OF MERCHANTABILITY OR FITNESS FOR A PARTICULAR PURPOSE, ARE EXPRESSLY EXCLUDED AND DECLINED.

SENSIRION is only liable for defects of this product arising under the conditions of operation provided for in the data sheet and proper use of the goods. SENSIRION explicitly disclaims all warranties, express or implied, for any period during which the goods are operated or stored not in accordance with the technical specifications.

SENSIRION does not assume any liability arising out of any application or use of any product or circuit and specifically disclaims any and all liability, including without limitation consequential or incidental damages. All operating parameters, including without limitation recommended parameters, must be validated for each customer's applications by customer's technical experts. Recommended parameters can and do vary in different applications.

SENSIRION reserves the right, without further notice, (i) to change the product specifications and/or the information in this document and (ii) to improve reliability, functions and design of this product.

Copyright© 2001-2009, SENSIRION.

CMOSens® is a trademark of Sensirion

All rights reserved.

PEEK™ is a trademark of Victrex PLC

Teflon® and Tefzel® are registered trademarks of DuPont Corporation

Duran® is a trademark of the SCHOTT-Group

7.4 RoHS and WEEE Statement

The LG16 product family complies with requirements of the following directives:

EU Directive 2002/96/EC on waste electrical and electronic equipment(WEEE), OJ13.02.2003; esp. its Article 6 (1) with Annex II.

EU Directive 2002/95/EC on the restriction of the use of certain hazardous substances in electrical and electronic equipment (RoHS), OJ 13.02.2003; esp. its Article 4.



Headquarter and Sales Offices

SENSIRION AG
Laubisruetistr. 50
CH-8712 Staefa ZH
Switzerland

phone: +41 44 306 40 00
fax: +41 44 306 40 30
info@sensirion.com
www.sensirion.com

Sensirion AG (Germany)
phone: +41 44 927 11 66
info@sensirion.com
www.sensirion.com

Sensirion Inc., USA
phone: +1 805 409 4900
info_us@sensirion.com
www.sensirion.com

Sensirion Japan Co. Ltd.
phone: +81 3 3444 4940
info@sensirion.co.jp
www.sensirion.co.jp

Sensirion Korea Co. Ltd.
phone: +82 31 345 0031 3
info@sensirion.co.kr
www.sensirion.co.kr

Sensirion China Co. Ltd.
phone: +86 755 8252 1501
info@sensirion.com.cn
www.sensirion.com.cn

To find your local representative, please visit www.sensirion.com/contact